

### Construction

The **GEMÜ C38 SonicLine®** flowmeter is an ultra-sonic flowmeter operating according to the phase difference method. The metering tube is made of PFA or TFM and can be directly integrated into the piping system by standard flare unions. The medium only contacts the metering tube. The electronic housing is made of PP. The connection cables are PTFE coated.

### Features

- GEMÜ C38 SonicLine® is particularly suitable for flow measurement of ultra high purity chemicals.
- All medium wetted parts are made of High Purity PFA or TFM
- GEMÜ C38 SonicLine® can be used both as a flowmeter and as a dosing instrument.
- Flow measurement is made according to the transit time difference method by means of ultra-sonic sensors.
- Parameterisation by means of converter and **FlowSoft™** configuration software

### Advantages

- High accuracy and repeatability
- No moving parts in the metering tube and thus subject to low wear
- In-line configuration
- Suitable for very dynamic processes (dosing time < 1s)
- Compact design
- Excellent chemical resistance
- Minimal deadlegs
- Integrated dosing function with preselection and correction quantity



Sectional drawing - metering tube

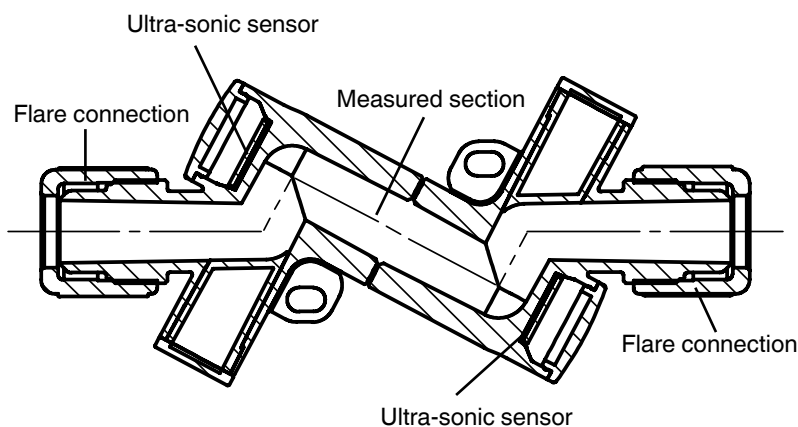

For dimensions and  $K_v$  values see page 3

**GEMÜ® C38**  
**SonicLine®**

Technical data

Working medium

Inert and corrosive liquid media - particularly High Purity media - which have no negative impact on the physical and chemical properties of the metering tube material.

Operating pressure

Max. 6 bar

Operating temperature

Ambient temperature	-20° ... 60° C
Medium temperature	0° ... 80° C
Storage temperature	-20° ... 60° C

Material

Electronics housing material	PP
Metering tube material	PFA or TFM

Flow direction

Flow direction acc. to arrow on housing

General information

Protection class to EN 60529	IP 65
Mounting position	- vertical riser pipe recommended - with horizontal mounting position the flowmeter must be mounted rising in flow direction
Inlet distance	3/8" 5 cm 1/2" 5 cm 3/4" 40 cm 1" 60 cm
Outlet distance	3/8" 0 cm 1/2" 0 cm 3/4" 20 cm 1" 20 cm
Min. backpressure at outlet	0.3 bar
Special feature	filled pipelines required

\*Note: Select the mounting position so that gas bubbles can escape from the flowmeter independently.

Electrical Data

<b>Power supply</b>		
Power supply	U <sub>v</sub> = 24 V DC	
Power consumption	3.6 W	
<b>Output signals</b>		
<b>Analogue output</b>		
Analogue output	0/4-20 mA / active (Version U41) 0-10 V / active (Version U11)	
<b>Digital outputs</b>		
Output 1	Open Collector (npn or pnp)	
Output 2	Open Collector (npn or pnp)	
Switching voltage	max. 30 V DC	
Switching current	max. 80 mA (pnp and npn transistors)	
Pulse rate	max. 10 kHz	
<b>Functions digital outputs</b>		
The function of the 2 outputs can be set using the <b>FlowSoft™</b> configuration software:		
	- pulse output	
	- empty tube message	
	- dosing output	
	- negative alarm	
	- limit value	
For inductive load a free-wheeling diode must be built in parallel to the coil. A pull up / pull down resistor may be necessary for connection to a PLC.		
<b>Input signals</b>		
<b>Digital inputs</b>		
Input 1	24 V DC	
<b>Functions digital input</b>		
The function can be set using <b>FlowSoft™</b> :		
	- dosing start	
	- creepage on / off	
	- offset trimming	
	- reset volume counter	
<b>Electrical connection</b>		
Input / output signals	10-core cable	
Cable length	5 m (PTFE coated) optional 8-pin M12x1 standard plug (without cable)	
<b>Measurement data</b>		
Measuring range for pos. flow direction (in arrow direction)		
3/8" LowFlow	0,5...100 ml/s	0,03...6 l/min
3/8"	1,5...100 ml/s	0,09...6 l/min
1/2"	5,0...400 ml/s	0,3...24 l/min
3/4"	15,0...1000 ml/s	0,9...60 l/min
1"	20,0...2000 ml/s	1,2...120 l/min
<b>Accuracy / Reproducibility</b>		
Reference conditions	Factory calibration with water at 20 °C	
Accuracy	± 1% v. M. ± 3 mm/s (v. M. = of current value)	
Reproducibility	0.5%	
<b>Parameterisation</b>	By converter and <b>FlowSoft™</b> configuration software (not included in the scope of delivery)	
<b>Interfaces</b>		
PC Interface	RS 485 (Parameterisation by RS 485 / USB Converter and <b>FlowSoft™</b> configuration software)	

Technical data

Measuring range, Kv / Cv values

Connection	Nominal size		Measuring range		Kv value [m <sup>3</sup> /h]	Cv value [gal/min]
	Inch	DN	[ml/s]	[l/min]		
Flare Connection	3/8"	6	1.5 - 100	0.09 - 6	0.70	0.82
	1/2"	10	5.0 - 400	0.30 - 24	1.65	1.93
	3/4"	15	15 - 1000	0.90 - 60	4.34	5.07
	1"	20	20 - 2000	1.20 - 120	8.80	10.30
	Measuring range - Low Flow					
	3/8"	6	0.5 - 100	0.03 - 6	0.70	0.82

Measurement deviations (H2O, 20 °C)

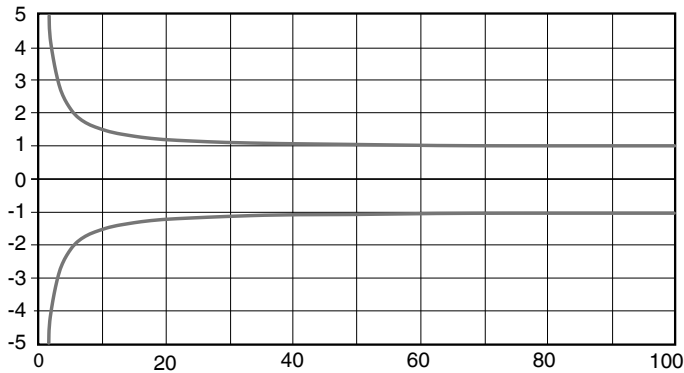

Calibration via configuration software (**FlowSoft™**) may be necessary for other media and operating temperatures. The GEMÜ USB converter C38000ZC23C10 is required for this.

Electrical connections

10 wire cable (standard)

Colour	Function
Black	Uv, GND supply
Red	Uv, 24 V DC supply voltage
Brown	U+, digital output Q1
Orange	U+, digital output Q2
Grey	U-, GND output 1, output 2
Violet	I+ / U+, analog output
Blue	I- / U-, analog output
Yellow	RS 485 A
Green	RS 485 B
White	Digital input I1

Shield must be connected to earth ground in the control cabinet.

M12x1 plug

Pin	Function
1	Uv, GND supply
2	U+, digital output Q1
3	Uv, GND supply U-, GND output Q1, output Q2
4	I- / U-, analog output
5	U+, digital output Q2
6	I+ / U+, analog output
7	RS 485 A
8	RS 485 B
8	Digital input I1

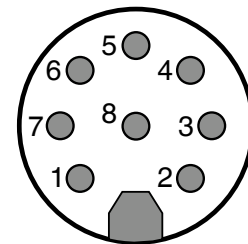

Dimensions [mm]

Nominal size		A	B	C	D	E	F	G	Weight [kg]
Inch	DN								
3/8"	6	218.0	120.0	79.0	16	77.0	63	48	1.3
1/2"	10	219.5	120.0	79.0	16	78.5	64	48	1.3
3/4"	15	227.0	120.0	82.0	19	82.0	64	48	1.3
1"	20	251.0	120.0	91.5	25	94.0	64	48	1.6

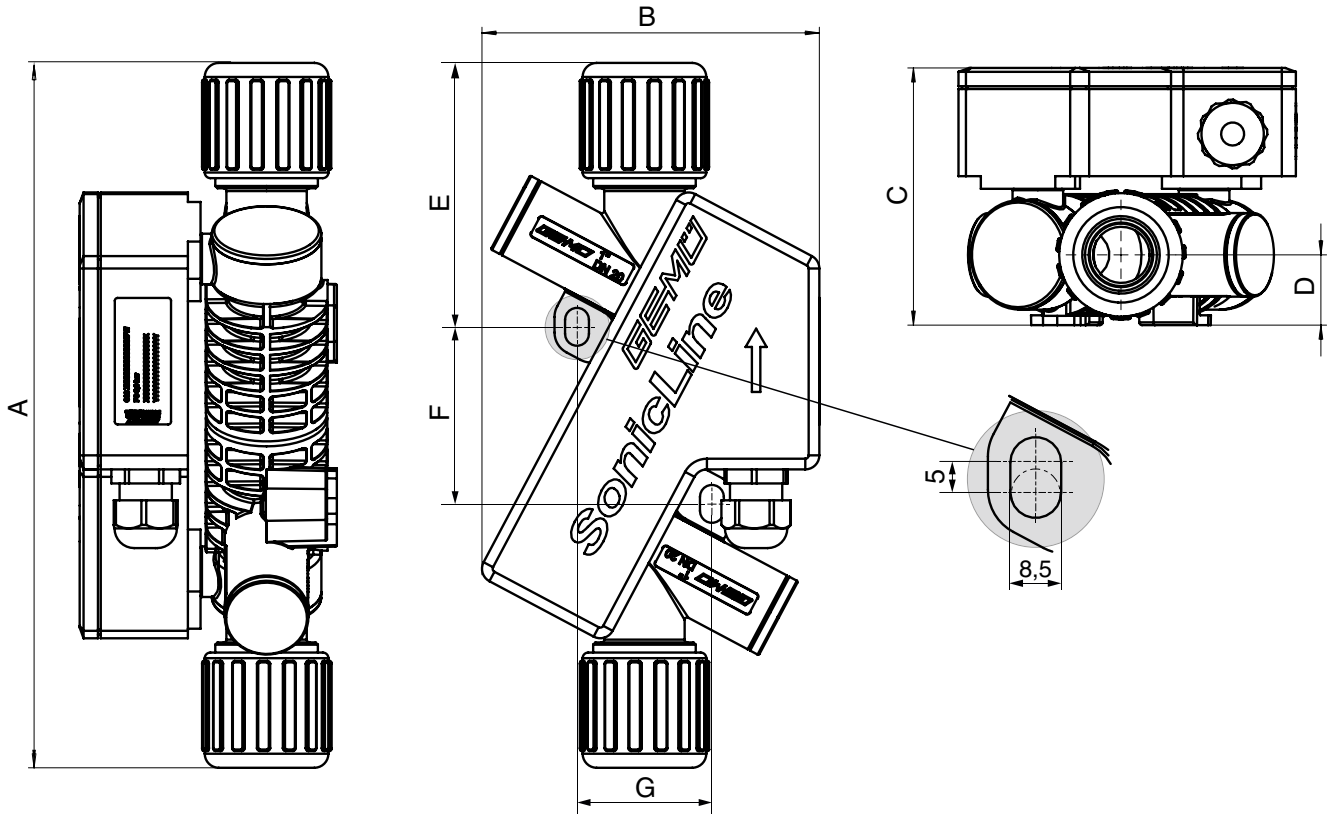

**Order data**

Nominal size	Code
3/8" (DN 6)	6
1/2" (DN 10)	8
3/4" (DN 15)	12
1" (DN 20)	16

Body configuration	Code
Straight through	D

Connection	Code
Flare connection with C-PFA union nut	73
Flare connection with PVDF union nut	75
Flare connection with PFA union nut	77

Body material	Code
PFA, Perfluoralkoxy	30

Device version	Code
Measuring transducer 0 - 10 V 1 pulse output, 1 switching output, 1 switching input	U11
Measuring transducer 4 - 20 mA 1 pulse output, 1 switching output, 1 switching input	U41

Option	Code
Standard, 5 m cable	00
M12x1 plug, 8pin	M8

Voltage/Frequency	Code
24 V DC	C1

Measuring range*	Code
3/8" (DN 6) 0.03...6 l/min (LowFlow)	AL
* Information only required for LowFlow version	

Version	Code
High Purity, White	HPW

Order example	C38	6	D	75	30	U41	00	C1	AL	HPW
Type	C38									
Nominal size (code)		6								
Body configuration (code)			D							
Connection (code)				75						
Body material (code)					30					
Device version (code)						U41				
Option (code)							00			
Voltage/frequency (code)								C1		
Measuring range* (code)									AL	
Version: High Purity, White (code)										HPW

\* Information only required for LowFlow version

**Accessories**



GEMÜ C38000ZC23C10  
Converter for C38 SonicLine®  
incl. FlowSoft™ configuration  
software for C38 SonicLine®

For further flowmeters, High purity products,  
accessories and other products, please see our  
Product Range catalogue and Price List. Contact GEMÜ.